

STARTING SYSTEM

ON-VEHICLE INSPECTION

ST04X-01

NOTICE:

Before changing the starter, check the following items again:

- Connector connection
- Accessory installation, e.g.: theft deterrent system

STARTER COMPONENTS

ST04Y-04

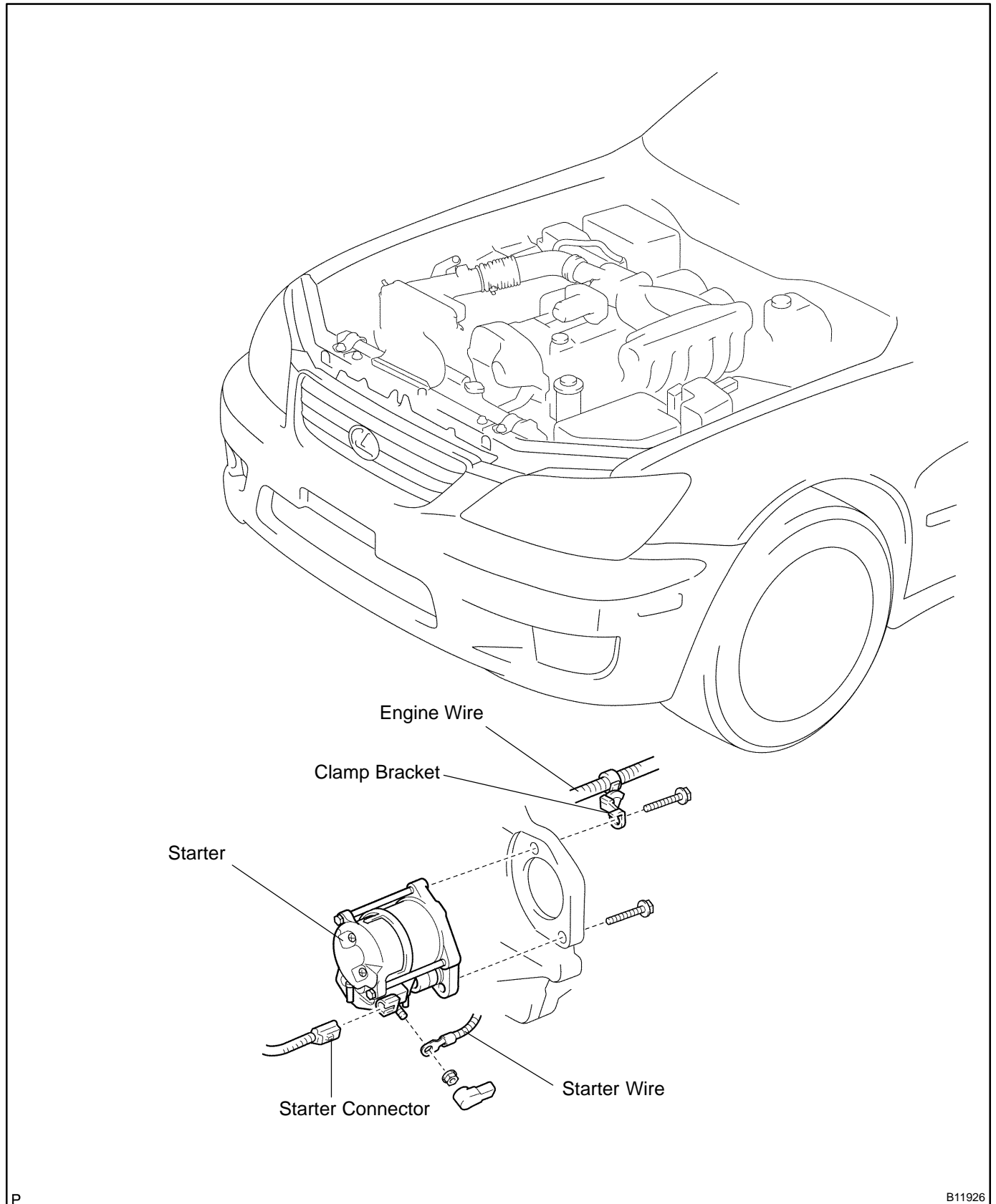

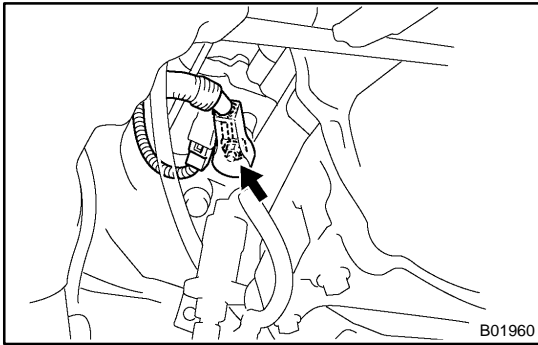

REMOVAL

REMOVE STARTER

- (a) Remove the rubber cap and nut, and disconnect the starter wire.
- (b) Disconnect the starter connector.

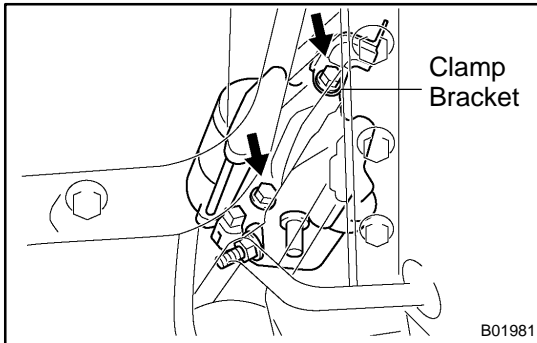

- (c) Remove the 2 bolts and starter.

Torque: 37 N·m (380 kgf-cm, 27 ft-lbf)

HINT:

At time of the installation, when installing the upper bolt, tighten it together with the clamp bracket.

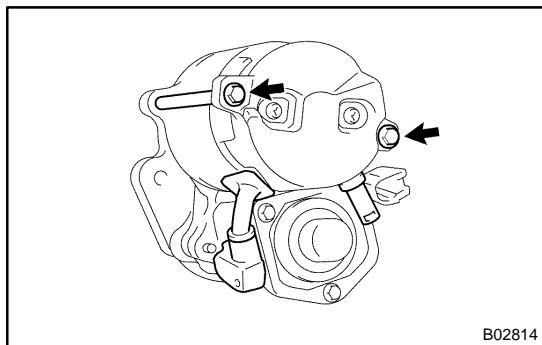

DISASSEMBLY

1. REMOVE DUST PROTECTOR

2. REMOVE FIELD FRAME AND ARMATURE

- (a) Remove the nut, and disconnect the lead wire from the magnetic switch terminal.

Torque: 5.9 N·m (60 kgf·cm, 52 in.-lbf)

- (b) Remove the 2 through bolts.

Torque: 5.9 N·m (60 kgf·cm, 52 in.-lbf)

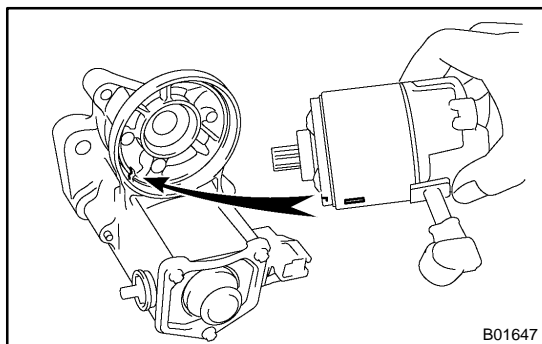

- (c) Pull out the field frame together with the armature.

HINT:

At the time of reassembly, align the protrusion of the field frame with the cutout of the magnetic switch.

- (d) Remove the O-ring from the field frame.

HINT:

At the time of reassembly, use a new O-ring.

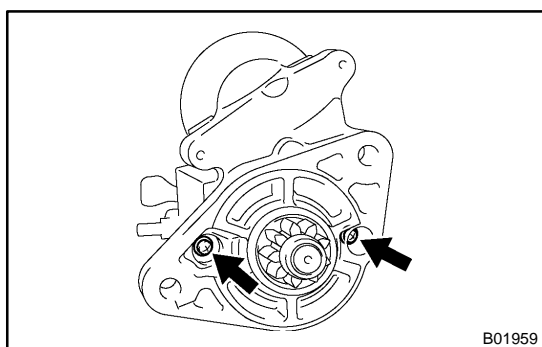

3. REMOVE STARTER HOUSING, CLUTCH ASSEMBLY AND GEAR

- (a) Remove the 2 bolts.

Torque: 5.9 N·m (60 kgf·cm, 52 in.-lbf)

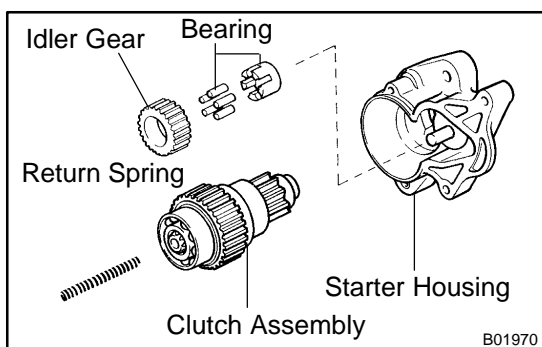

- (b) Remove the starter housing, idler gear, bearing, clutch assembly and return spring from the magnetic switch.

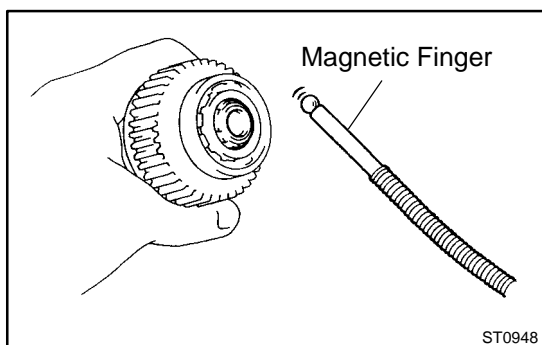

4. REMOVE STEEL BALL

Using a magnetic finger, remove the steel ball from the clutch shaft hole.

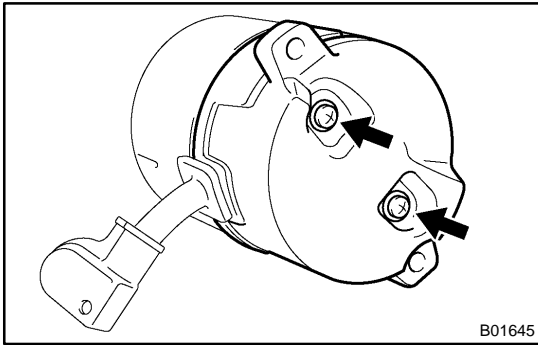
**5. REMOVE BRUSH HOLDER**

- (a) Remove the 2 screws and end cover from the field frame.
Torque: 1.5 N·m (15 kgf·cm, 13 in.-lbf)
- (b) Remove the O-ring from the field frame.

HINT:

At the time of reassembly, use a new O-ring.

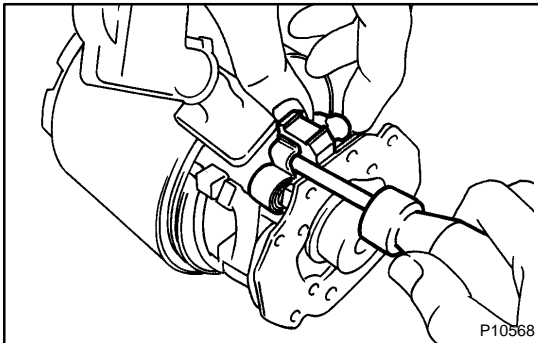

- (c) Using a screwdriver, hold the spring back and disconnect the brush from the brush holder. Disconnect the 4 brushes, and remove the brush holder.

NOTICE:

At the time of reassembly, check that the positive (+) lead wires are not grounded.

6. REMOVE ARMATURE FROM FIELD FRAME

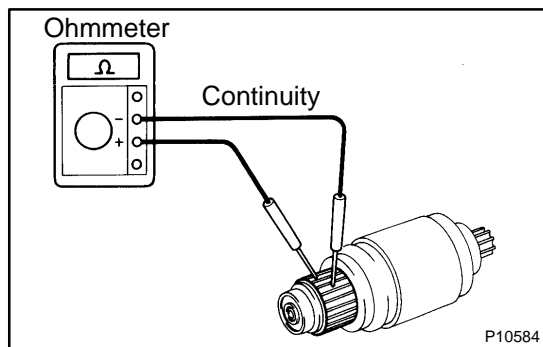

INSPECTION

1. INSPECT ARMATURE COIL

- (a) Check the commutator for open circuit.
Using an ohmmeter, check that there is continuity between the segments of the commutator.
If there is no continuity between any segment, replace the armature.

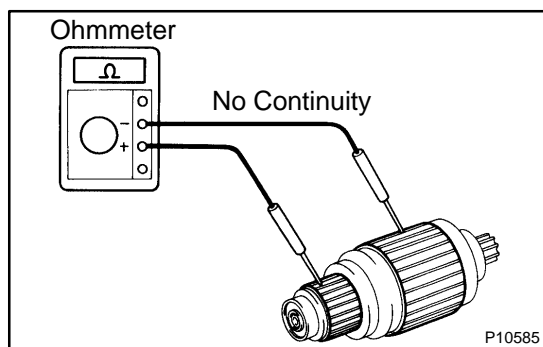

- (b) Check the commutator for ground.
Using an ohmmeter, check that there is no continuity between the commutator and armature coil core.
If there is no continuity, replace the armature.

2. INSPECT COMMUTATOR

- (a) Check the commutator for the dirty and burnt surfaces.
If the surface is dirty or burnt, correct it with sandpaper (No.400) or on a table.

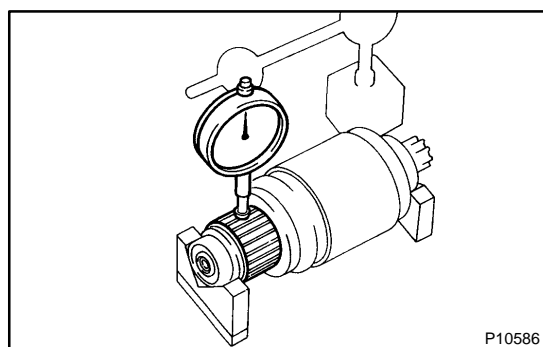

- (b) Check for the commutator circle runout.
(1) Place the commutator on V-blocks.
(2) Using a dial gauge, measure the circle runout.
Maximum circle runout: 0.05 mm (0.0020 in.)
If the circle runout is greater than maximum, correct it on a lathe.

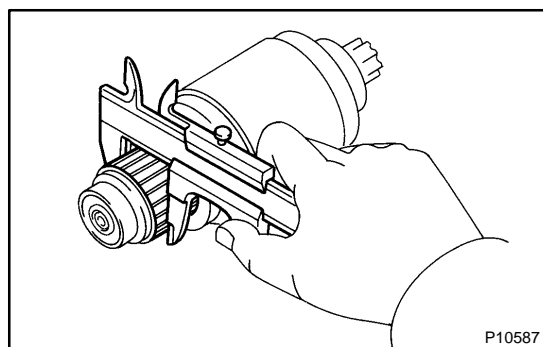

- (c) Using a vernier caliper, measure the commutator diameter.
Standard diameter: 30.0 mm (1.181 in.)
Minimum diameter: 29.0 mm (1.412 in.)
If the diameter is less than minimum, replace the armature.

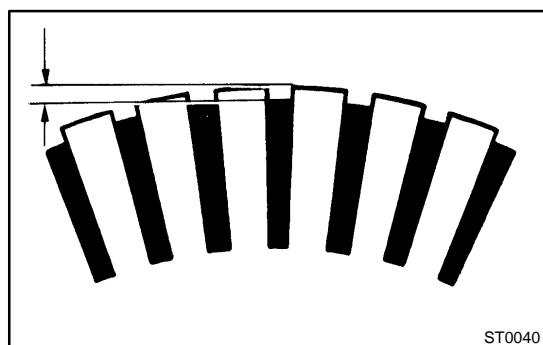

- (d) Check that the undercut depth is clean and free of foreign materials. Smooth out the edge.
Standard undercut depth: 0.6 mm (0.024 in.)
Minimum undercut depth: 0.2 mm (0.008 in.)
If the undercut depth is less than minimum, correct it with a hacksaw blade.

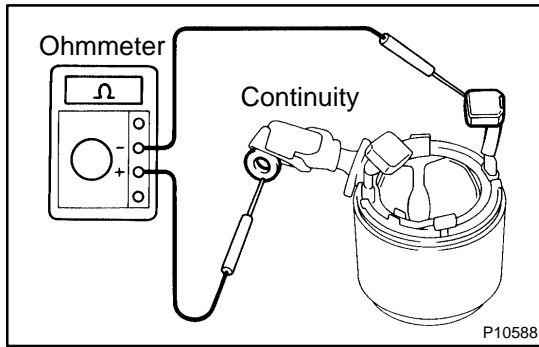

3. INSPECT FIELD COIL

- (a) Check the field coil for open circuit.

Using an ohmmeter, check that there is continuity between the lead wire and field coil brush lead.

If there is no continuity, replace the field frame.

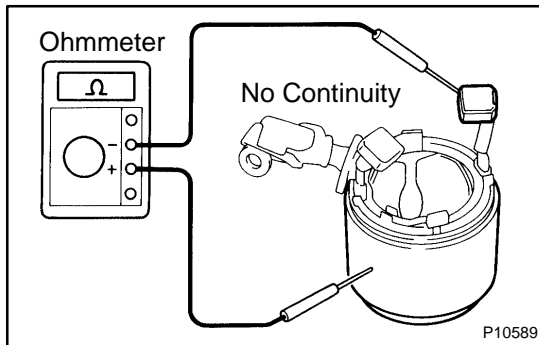

- (b) Check the field coil for ground.

Using an ohmmeter, check that there is no continuity between the field coil end and field frame.

If there is continuity, replace the field frame.

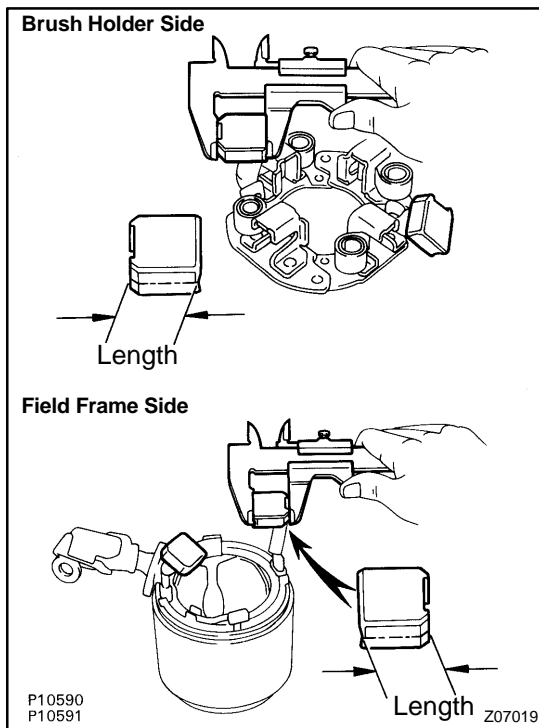

4. INSPECT BRUSHES

Using a vernier caliper, measure the brush length.

Standard length: 15.5 mm (0.610 in.)

Minimum length: 10.0 mm (0.394 in.)

If the length is less than minimum, replace the brush holder and field frame.

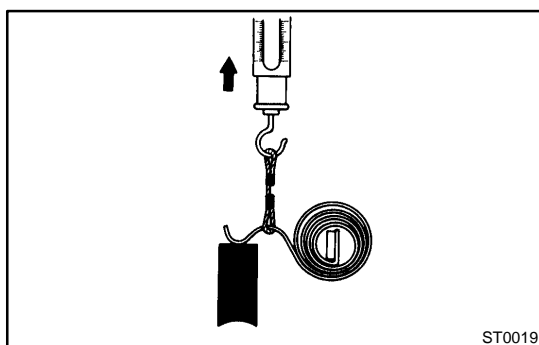

5. INSPECT BRUSH SPRINGS

Check the brush spring load. Take the pull scale reading the instant the brush spring separates from the brush.

Standard spring installed load:

17.6 - 23.5 N (1.8 - 2.4 kgf, 3.9 - 5.3 lbf)

Minimum spring installed load:

11.8 N (1.2 kgf, 2.6 lbf)

If the installed load is less than minimum, replace the brush springs.

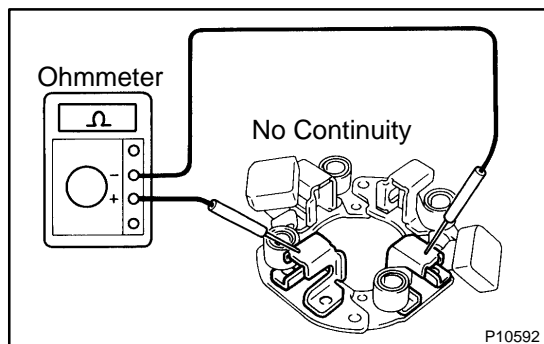

6. INSPECT BRUSH HOLDER

Check the brush holder insulator. Using an ohmmeter, check that there is no continuity between the positive (+) and negative (-) brush holders.

If there is continuity, repair or replace the brush holder.

7. INSPECT CLUTCH AND GEAR

- (a) Check the gear teeth on the pinion gear, idle gear and the clutch assembly for wear or damage.

If damaged, replace the gear or clutch assembly.

If damaged, also check the drive plate ring gear for wear or damage.

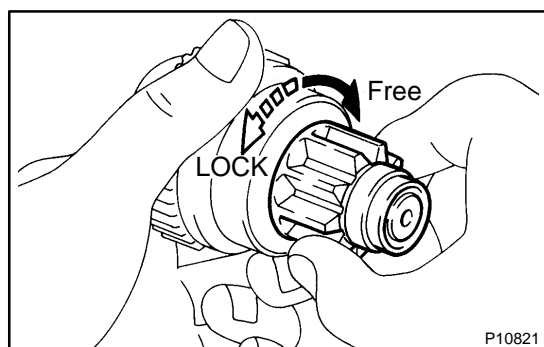

- (b) Check the clutch pinion gear.

Rotate the pinion gear counterclockwise, and check that it turns freely. Try to rotate the pinion gear clockwise and check that it locks.

If necessary, replace the clutch assembly.

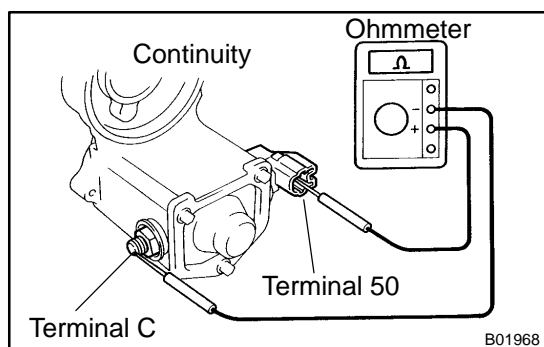

8. INSPECT MAGNETIC SWITCH

- (a) Check the pull-in coil for open circuit.

Using an ohmmeter, check that there is continuity between terminals 50 and C.

If there is no continuity, check and replace the magnetic switch.

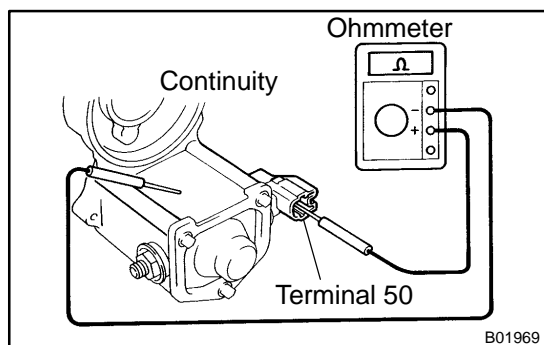

- (b) Check the hold-in coil for open circuit.

Using an ohmmeter, check that there is continuity between terminal 50 and the switch body.

If there is no continuity, replace the magnetic switch.

9. INSPECT BEARING

Turn the bearing by hand and while apply inward force.

If resistance is felt or bearing sticks, replace the bearing (See page [ST-10](#)).

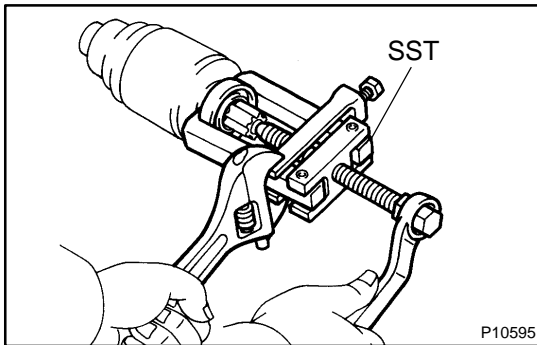

REPLACEMENT

1. REPLACE FRONT BEARING

- (a) Using SST, remove the bearing.
SST 09286-4601 1

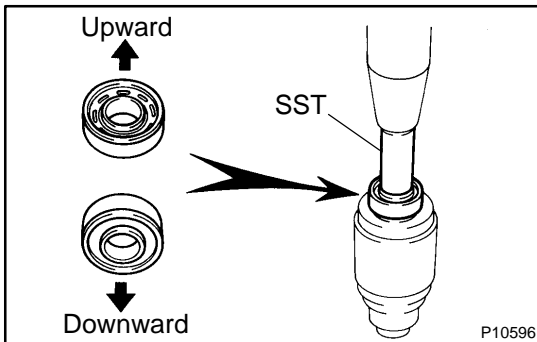

- (b) Using SST and a press, press in a new bearing.

NOTICE:

Be careful of the bearing installation direction.

SST 09820-00031

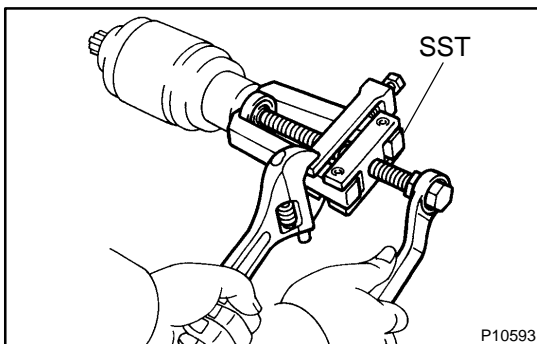

2. REPLACE REAR BEARING

- (a) Using SST, remove the bearing.
SST 09286-4601 1

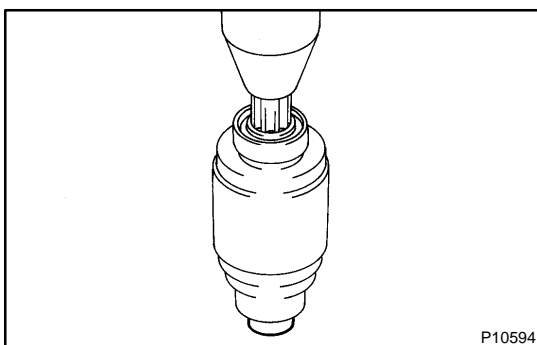

- (b) Using a press, press in a new rear bearing.

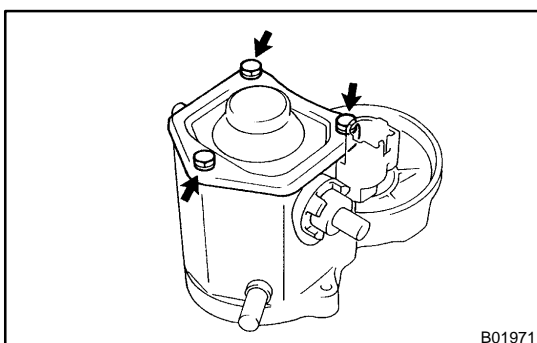

3. REPLACE MAGNETIC SWITCH TERMINAL PARTS

- (a) Remove the 3 bolts, end cover, gasket and plunger.

STARTING - STARTER

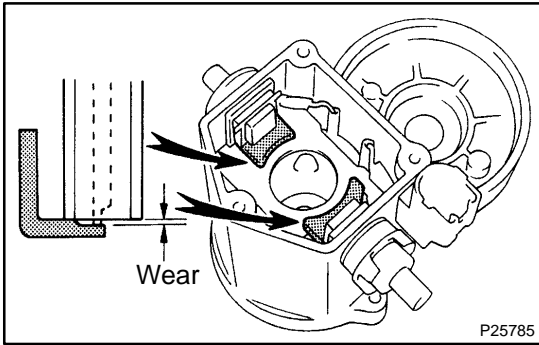

(b) Using vernier calipers, measure the contact plate for depth of wear.

Maximum wear: 0.9 mm (0.035 in.)

If the depth of wear is greater than the maximum, replace the contact plate.

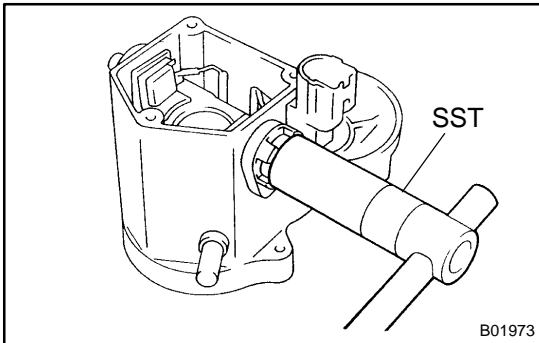

(c) Remove the terminal kit parts.

(1) Using SST, loosen the terminal nuts.

SST 09810-38140

(2) Terminal C:

Remove the terminal nut, wave washer, terminal insulator (outside), O-ring, terminal bolt, contact plate and terminal insulator (inside).

(3) Terminal 30:

Remove the terminal nut, wave washer, terminal insulator (outside), packing, O-ring, terminal bolt, contact plate and terminal insulator (inside).

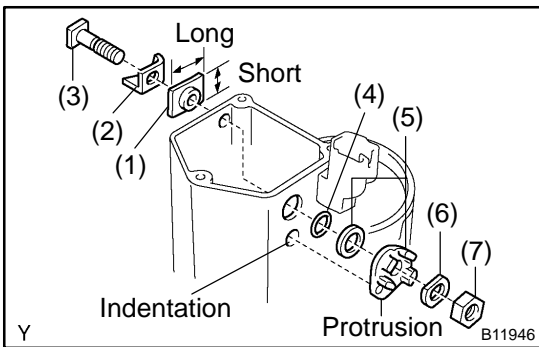

(d) Temporarily install new terminal 30 kit parts:

(1) Install a new terminal insulator (inside).

(2) Install a new contact plate.

(3) Install a new terminal bolt.

(4) Install a new O-ring.

(5) Install a new packing and terminal insulator (outside).

Install the packing to the terminal insulator, and install them.

HINT:

Match the protrusion of the insulator with the indentation of the housing.

(6) Install a new wave washer.

(7) Install a new terminal nut.

NOTICE:

Be careful to install the terminal insulators in the correct direction.

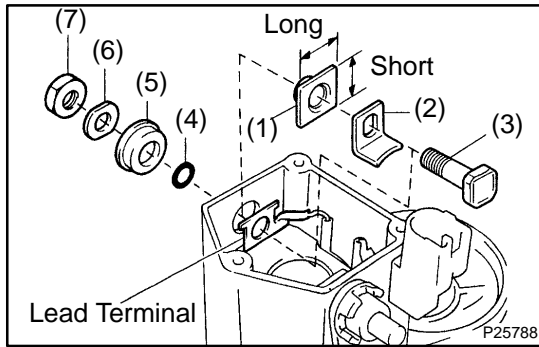

- (e) Temporarily install new terminal C kit parts:
- (1) Install a new terminal insulator (inside).
 - (2) Install a new contact plate.
 - (3) Install a new terminal bolt.
 - (4) Install a new O-ring.
 - (5) Install a new terminal insulator (outside).
 - (6) Install a new wave washer.
 - (7) Install a new terminal nut.

NOTICE:

Be careful to install the terminal insulators in the correct direction.

- (f) Temporarily tighten the terminal nuts.

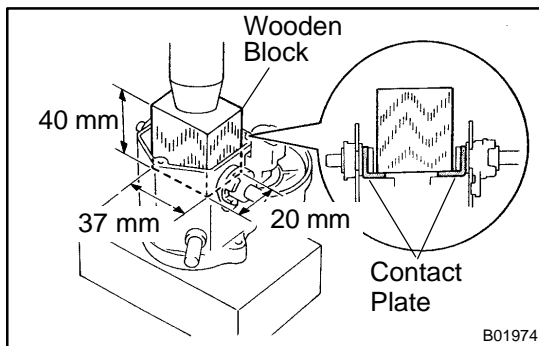

- (g) Tighten the terminal nut
- (1) Put a wooden block on the contact plate and press it down with a hand press.

Dimensions of wooden block:

20 x 37 x 40 mm (0.79 x 1.46 x 1.57 in.)

Press force:

981 N (100 kgf, 221 lbf)

NOTICE:

- **Check the diameter of the hand press ram. Then calculate the gauge pressure of the press when 981 N (100 kgf, 221 lbf) of force is applied.**

Gauge pressure:

$$(\text{kgf/cm}^2) = \frac{100 \text{ kgf}}{\left(\frac{\text{Ram diameter (cm)}}{2} \right)^2 \times 3.14 (\pi)}$$

$$(\text{psi}) = \frac{221 \text{ lbf}}{\left(\frac{\text{Ram diameter (in.)}}{2} \right)^2 \times 3.14 (\pi)}$$

$$(\text{kPa}) = (\text{kgf/cm}^2) \times 98.1$$

$$(\text{kPa}) = (\text{psi}) \times 6.9$$

- **If the contact plate is not pressed down with the specified pressure, the contact plate may tilt due to coil deformation or the tightening of the nut.**

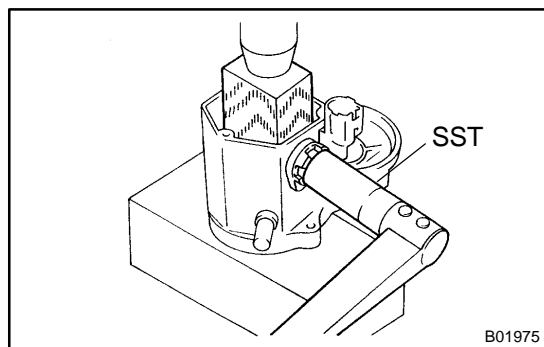

- (2) Using SST, tighten the nuts to the specified torque.
SST 09810-38140

Torque: 17 N·m (173 kgf-cm, 13 ft-lbf)

NOTICE:

If the nut is over tightened, it may cause cracks on the inside of the insulator.

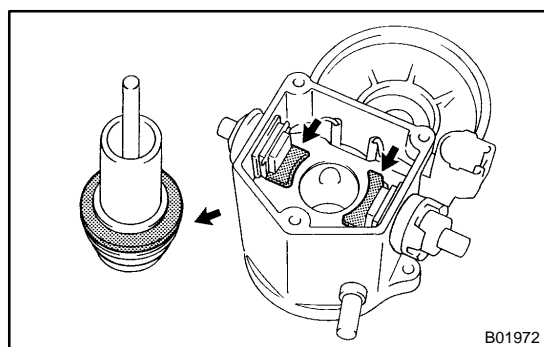

- (h) Clean the contact surfaces of the remaining contact plate and plunger with a dry shop rag.
(i) Reinstall the plunger, new gasket, end cover and lead clamp with the 3 bolts.

Torque: 2.5 N·m (26 kgf-cm, 22 in.-lbf)

REASSEMBLY

Reassembly is in the reverse order of disassembly (See page [ST-5](#)).

HINT:

Before reassembly, use high-temperature grease to lubricate the bearings and gears.

TEST

NOTICE:

These tests must be done within 3 to 5 seconds to avoid burning out the coil.

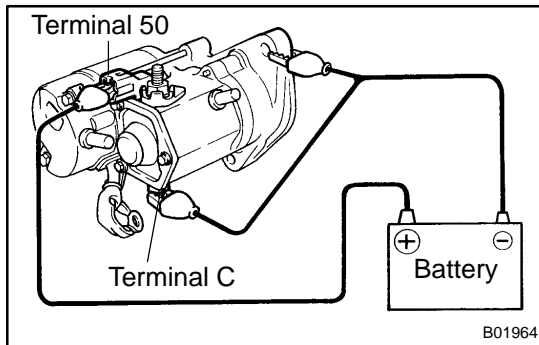

1. DO PULL-IN TEST

- (a) Disconnect the field coil lead wire from terminal C.
- (b) Connect the battery to the magnetic switch as shown. Check that the pinion gear moves outward.

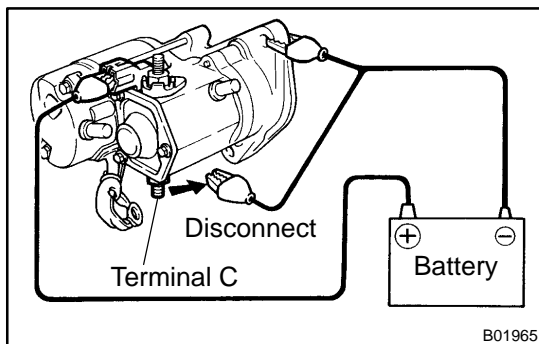

2. DO HOLD-IN TEST

While connected as above with the pinion gear out, disconnect the negative (-) lead from terminal C. Check that the pinion gear remains out.

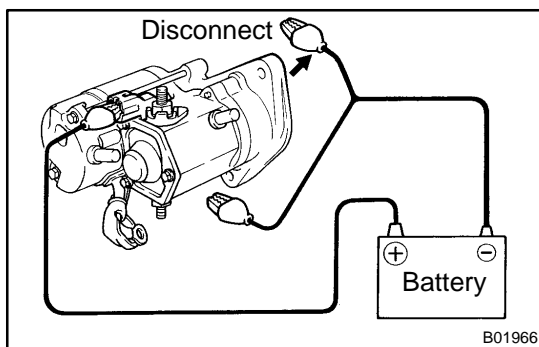

3. INSPECT CLUTCH PINION GEAR RETURN

Disconnect the negative (-) lead from the starter body. Check that the pinion gear returns inward.

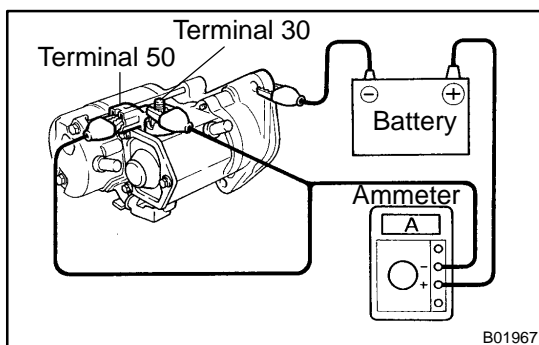

4. DO NO-LOAD PERFORMANCE TEST

- (a) Connect the battery and ammeter to the starter as shown.
- (b) Check that the starter rotates smoothly and steadily with the pinion gear moving out. Check that the ammeter shows the specified current.

Specified current: 90 A or less at 11.5 V

INSTALLATION

Installation is in the reverse order of removal (See page [ST-4](#)).

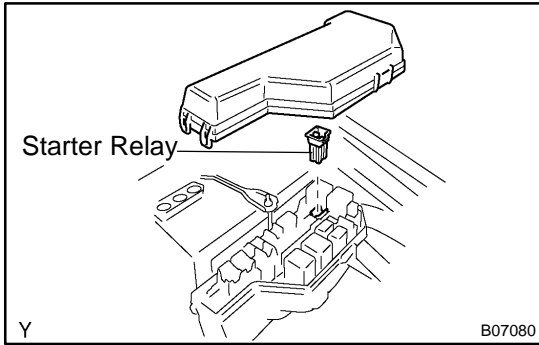

STARTER RELAY INSPECTION

ST003-01

1. REMOVE RELAY BOX COVER
2. REMOVE STARTER RELAY

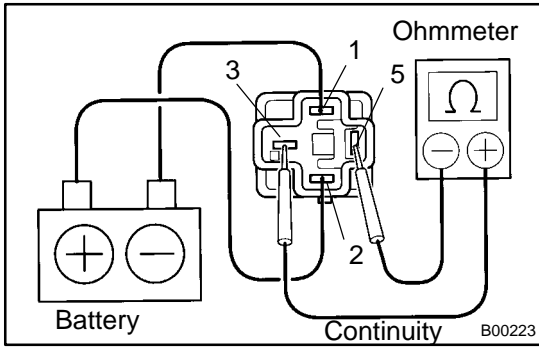

3. INSPECT STARTER RELAY

- (1) Using an ohmmeter, measure the resistance between the terminals.

Standard:

Tester Connection	Specified Condition
3 - 5	10 kΩ or higher
3 - 5	Below 1 Ω (Apply battery voltage to terminals 1 and 2)

If the resistance is not as specified, replace the relay.

4. REINSTALL STARTER RELAY
5. REINSTALL RELAY BOX COVER